

FEATURES

- Low leakage
- Low forward voltage drop
- High current capability
- High current surge
- High reliability
- High temperature soldering guaranteed:260°C/10 seconds at terminals
- Component in accordance to RoHS 2002/95/EC and WEEE 2002/96/EC

MECHANICAL DATA

- *Case*: JEDEC DO-15 molded plastic body
- *Terminals*: Plated axial leads, solderable per MIL-STD-750,Method 2026
- *Polarity*: Color band denotes cathode end
- *Mounting Position*: Any
- *Weight*: 0.014ounce, 0.39 gram

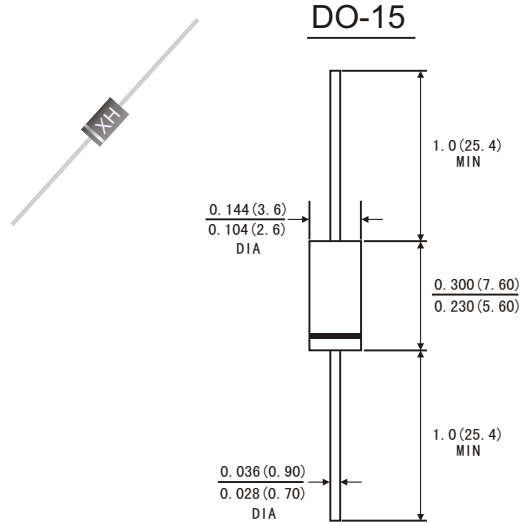

Dimensions in inches and (millimeters)

MAXIMUM RATINGS AND ELECTRICAL CHARACTERISTICS

(Rating at 25°C ambient temperature unless otherwise specified.Single phase ,half wave ,60Hz,resistive or inductive load. For capacitive load,derate current by 20%.)

		Symbols	FR 151	FR 152	FR 153	FR 154	FR 155	FR 156	FR 157	Units
Maximum Recurrent Peak Reverse Voltage		VRRM	50	100	200	400	600	800	1000	Volts
Maximum RMS Voltage		VRMS	35	70	140	280	420	560	700	Volts
Maximum DC Blocking Voltage		VDC	50	100	200	400	600	800	1000	Volts
Maximum Average Forward Rectified Current 0.375"(9.5mm)lead length at TA=55°C		I(AV)	1.5							Amps
Peak Forward Surge Current 8.3ms single half sine-wave superimposed on rated load (JEDEC method)		IFSM	50.0							Amps
Maximum Instantaneous Forward Voltage at 1.5 A		VF	1.2							Volts
Maximum DC Reverse Current at rated DC blocking voltage	TA=25°C	IR	5.0							μA
	TA=100°C		100							
Maximum reverse recovery time(Note1)		trr	150				250	500		ns
Typical junction capacitance(Note2)		CJ	30							pF
Operating junction and storage temperature range		TJ TSTG	-65 to +150							°C

Note: 1. Test conditions: IF=0.5A,IR=1.0A,IRR=0.25A.

2. Measured at 1MHz and applied reverse voltage of 4.0 Volts D.C.

FIG.1-TYPICAL FORWARD CURRENT DERATING CURVE

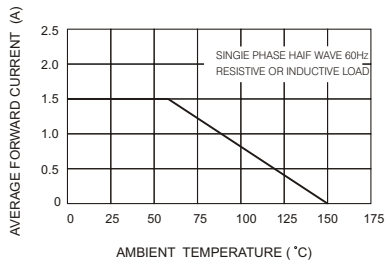

FIG.2-MAXIMUM NON-REPETITIVE FORWARD SURGE CURRENT

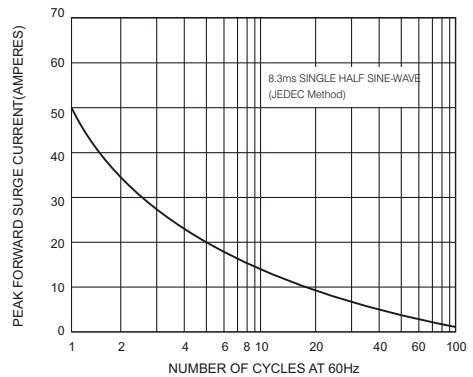

FIG.3-TYPICAL INSTANTANEOUS FORWARD CHARACTERISTICS

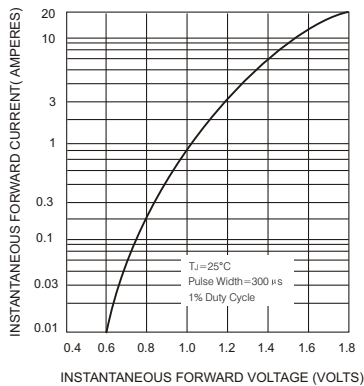

FIG.4-TYPICAL JUNCTION CAPACITANCE

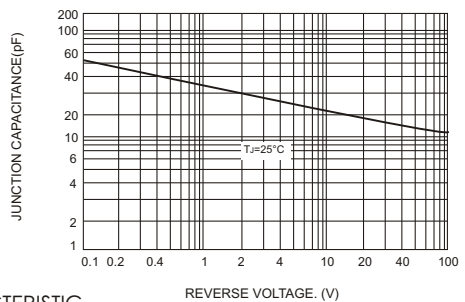
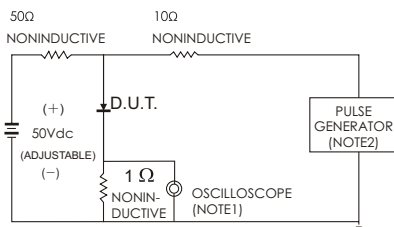

FIG.5-TEST CIRCUIT DIAGRAM AND REVERSE RECOVERY TIME CHARACTERISTIC



NOTES: 1. Rise Time=7ns max. input Impedance=1 megohm 22pF
2. Rise Time=10ns max. source Impedance=50 ohms

