

## FEATURES

- Plastic package has Underwriters Laboratory Flammability Classification 94V-0
- Fast switching for high efficiency
- Low forward voltage drop
- Single rectifier construction
- High surge capability
- For use in low voltage ,high frequency inverters, free wheeling ,and polarity protection applications
- High temperature soldering guaranteed:260 C/10 seconds, 0.25"(6.35mm)from case
- Component in accordance to RoHS 2002/95/EC and WEEE 2002/96/EC

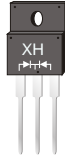

## ITO-220AB

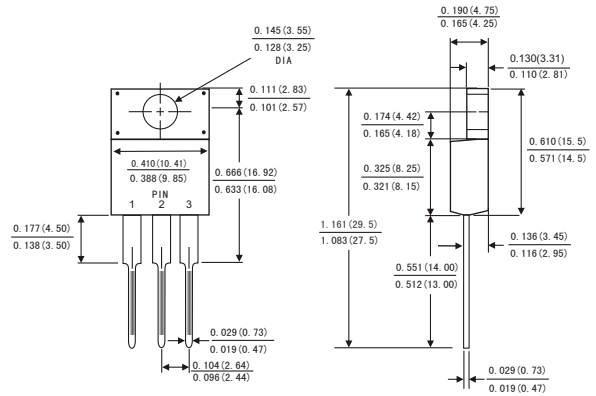

## MECHANICAL DATA

- Case: JEDEC ITO-220AB molded plastic body
- Terminals: Lead solderable per MIL-STD-750,method 2026
- Polarity: As marked.
- Mounting Position: Any
- Weight: 0.08ounce, 2.24 gram

## MAXIMUM RATINGS AND ELECTRICAL CHARACTERISTICS

(Ratings at 25°C ambient temperature unless otherwise specified ,Single phase ,half wave ,resistive or inductive load. For capacitive load,derate by 20%.)

	Symbols	MURF 1620CT	MURF 1640CT	MURF 1660CT	Units
Maximum repetitive peak reverse voltage	$V_{RRM}$	200	400	600	Volts
Maximum RMS voltage	$V_{RMS}$	140	280	420	Volts
Maximum DC blocking voltage	$V_{DC}$	200	400	600	Volts
Maximum average forward rectified current(see Fig.1)	Per leg	8.0			Amps
	Total device	16.0			
Peak forward surge current 8.3ms single half sine-wave superimposed on rated load (JEDEC method)	$I_{FSM}$	100			Amps
Maximum instantaneous forward voltage at 10.0 A(Note 1 )	$V_F$	0.975	1.3	1.7	Volts
Maximum instantaneous reverse current at rated DC blocking voltage(Note 1)	$T_A = 25^\circ\text{C}$	5	10		uA
	$T_A = 125^\circ\text{C}$	500			
Maximum Reverse Recovery Time (Note 2)	$T_{rr}$	35			ns
Typical thermal resistance (Note 3)	$R_{\theta JC}$	3.0			°C/W
Operating junction temperature range	$T_J$	-65 to +175			°C
Storage temperature range	$T_{STG}$	-65 to +175			°C

- Notes: 1. Pulse test: 30μs pulse width,1% duty cycle  
2. Reverse recovery test conditions  $I_F=0.5A, I_R=1.0A, I_{rr}=0.25A$   
3. Thermal resistance from junction to case

FIG.1-FORWARD CURRENT DERATING CURVE

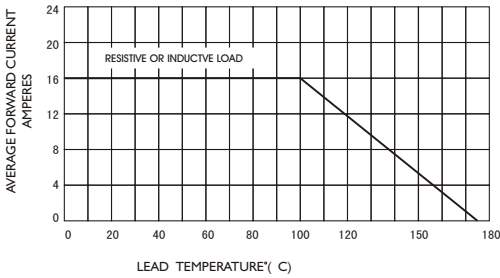

FIG.2-MAXIMUM NON-REPETITIVE PEAK FORWARD SURGE CURRENT

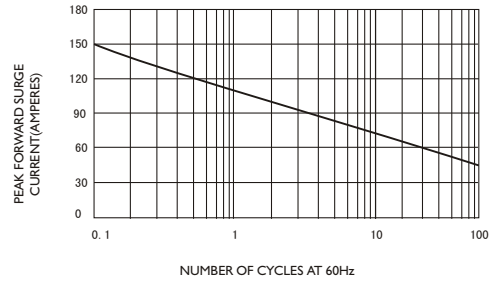

FIG.3-TYPICAL INSTANTANEOUS FORWARD CHARACTERISTICS

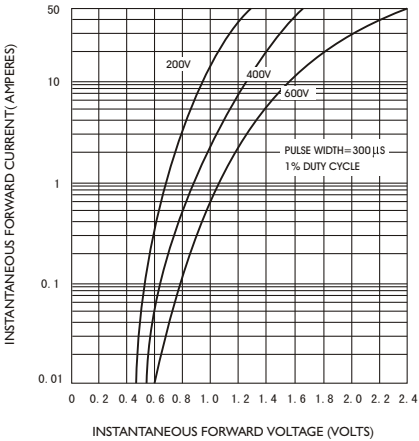

FIG.4-TYPICAL REVERSE CHARACTERISTICS

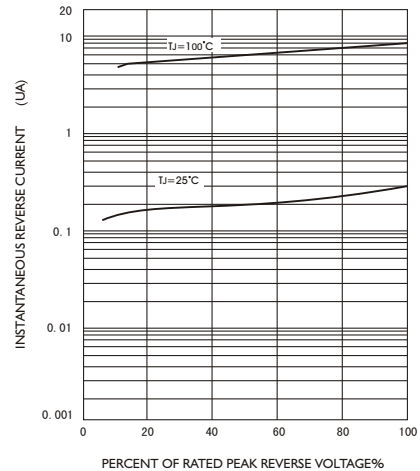

FIG.5-TYPICAL JUNCTION CAPACITANCE

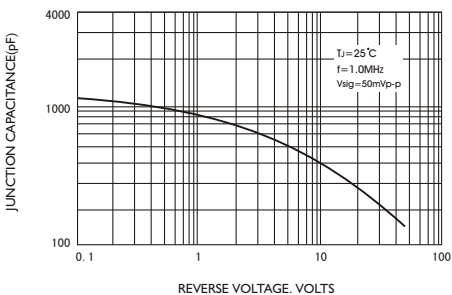

FIG.6-TYPICAL TRANSIENT THERMAL IMPEDANCE

